

# CASCOS

PROFESIONALES DE LA ELEVACIÓN



## ELEVADOR MONOCOLUMNA



# C125

Ref.

13167

Min

125 mm

kg

2.5Tn

kg

600 Kg.

W

400/230V - 3,7KW

↑

45"

FIABLE

SÓLIDO

INDEFORMABLE



SlenderTec™  
Super Strength Column Made in Germany



Made in Germany

El perfil **SlenderTec™** Super Strength Column Made in Germany permite fabricar columnas extremadamente resistentes y menos voluminosas.

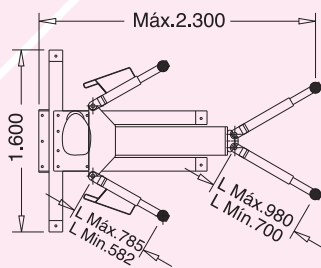
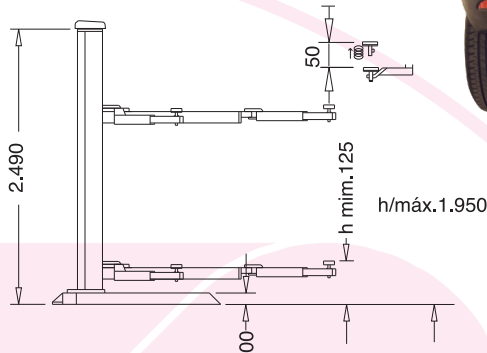
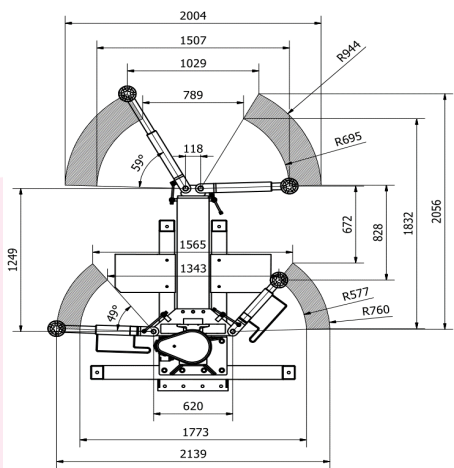

### Reversibilidad



CASCOS



2006/42/CE & EN - 1493:2011  
European Directives  
& Approved Standards



## ✓ Detalles exclusivos

El sistema de seguridad de brazos, con varilla roscada, permite las **mayores posibilidades de posicionamiento de brazos** bajo el vehículo, al ser de movimiento continuo.

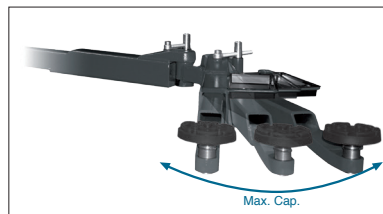
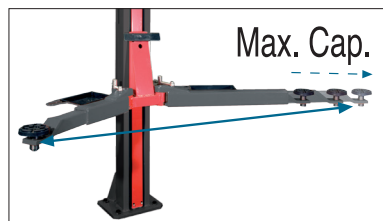
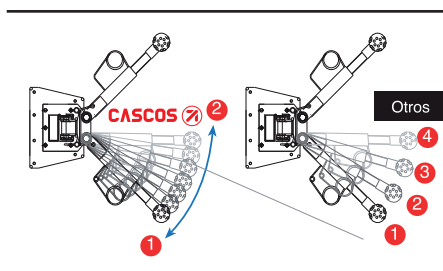

**Carga máxima HOMOLOGADA**  
¡En cualquier posición!

Los elevadores **CASCOS** a diferencia de otras alternativas en el mercado, soportan la **carga máxima independientemente de:**

- El reparto de la carga del vehículo (reversible).
- El ángulo y/o desplazamiento de los brazos.

Carros provistos de **rodamientos de acero de alta calidad**. Sistema con **mucho menor desgaste** que los que deslizan mediante pastillas de Nylon.

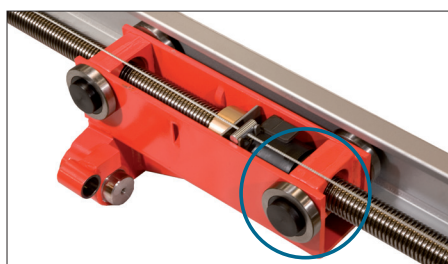

**Husillo laminado de 45 mm de diámetro**, con tuercas de alta calidad especialmente diseñadas que aseguran:

- Menor desgaste.
- Mayor duración.

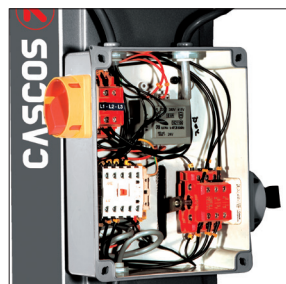
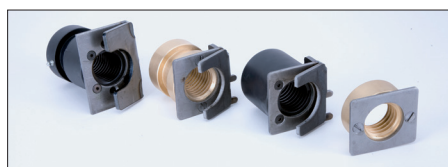

**Máxima fiabilidad**, mecánica y eléctrica.



Cadena de transmisión **integrada en la base**

CASCOS dispone de fijaciones al suelo para sus elevadores

## Accesorios

**Soporte magnético para herramientas**



**Kit magnético de aire**



**Enchufe integrado (fábrica)**



**Recambio original**

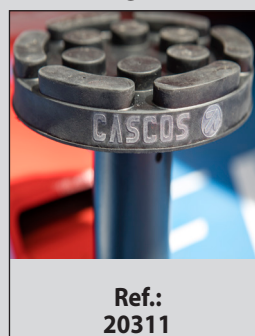

**Opcional**

